

ARC 490/590 Drawing the Twentieth Century Domestic Realm: A Personal History

Sergio López-Piñeiro

Fall 2009

Monday, 6.00 - 8.40 pm

230 Hayes Hall

Department of Architecture

University at Buffalo

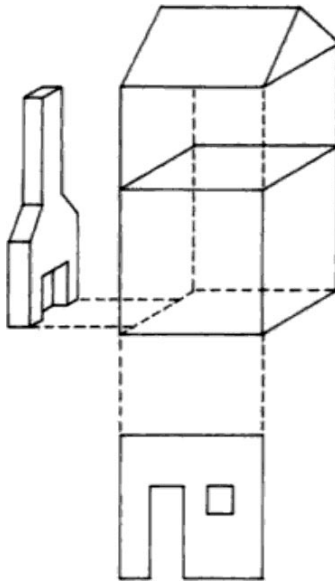

The objective of this course is to study houses that have contributed in determining the iconic qualities of our contemporary domestic realm. Focusing on specific architectural conditions, students will construct a personal and visual history of the domestic realm through the graphic analysis of some essential houses of the twentieth century. This drawing and thinking intensive seminar will focus on orthographic projection as the primary mode for conceptual and physical representation.

This is a 3.0 credit course and it is opened to undergraduate and graduate architecture students.